

WWW.TURNSTILEPARTS.COM

WANITA.SAVAGE@TURNSTILEPARTS.COM

CALL 303-816-1781

PRODUCT MANUAL

catrax
plus



INDEX

1 GUIDELINES	4
2 INTRODUCTION	4
3 CHARACTERISTICS	4
3.1 CATRAX Plus operating mechanisms.....	6
4 CATRAX PLUS ASSEMBLY / INSTALLATION	6
4.1 Visual inspection	6
4.2 Preparing the installation site.....	7
4.3 Installing the column	7
4.4 Mounting of arms and covers	8
4.5 Access to the CATRAX Plus internal components after assembly	9
5 INSTALLATION/ASSEMBLY OF OPTIONAL PRODUCTS	9
5.1 Card collection kit with chute	9
5.1.1 Connecting the card collection box to the control board	10
5.2 Pictogram kit	10
5.3 Counter.....	11
5.4 Power supply	11
5.5 Control board	12
5.5.1 Inputs	13
5.5.2 Outputs	14
5.5.3 Control board configuration – Dip Switch 1.....	16
5.5.4 Configuration examples	16
5.6 No-break power unit.....	16
5.6.1 Anti-panic device	17
5.7 Display	17
5.7.1 Display configuration and operation via software	18
5.7.2 Adjusting the display manually	20
5.7.3 Connection table.....	21
6 MAINTENANCE.....	21
6.1 Preventive and corrective maintenance procedures.....	21
6.2 Troubleshooting	23
7 TECHNICAL CHARACTERISTICS	23
8 WARRANTY AND TECHNICAL ASSISTANCE	25

1 GUIDELINES

Carefully read the instructions contained in this manual before assembling and installing the Catrax Plus turnstile. This will extend the life of the product and will enable you to fully benefit from all its features.

This product was not designed for outdoor use in unprotected areas.

Retain this manual for future reference.

Digicon reserves the right to upgrade the characteristics of its products at any time in order to incorporate technological advancements.

Digicon reserves the right to change the information contained in this manual without notice.

Digicon does not provide any warranty related to the information contained in this manual. Digicon cannot be held responsible for any errors this manual may contain or for any problems caused by its use.

The information contained in this manual is the exclusive property of Digicon and is protected by copyright laws.

This manual may not be copied, photocopied or translated in its entirety or in part, in any kind of medium, without Digicon's written permission.

2 INTRODUCTION

The CATRAX line of turnstiles was developed to be robust, reliable and esthetically pleasing. Its rounded lines house a sturdy blocking mechanism designed for very low maintenance.

CATRAX Plus serves all major access control technologies presently available, being acclaimed as the best option in turnstiles in the market.

This manual presents a detailed description of CATRAX Plus operation and components. To get to know other Digicon products, please visit our website at www.digicon.com.br or www.catrax.com.br.

3 CHARACTERISTICS

The CATRAX Plus is a column-type mini turnstile with three bidirectional arms finished with brushed stainless steel (AISI 304).



The column is available in two finishes: brushed stainless steel (AISI 304) or 1020 carbon steel with black or beige epoxy powder coating. It features fully rounded corners and a smooth surface with no exposed screws, in addition to a reinforced internal structure and plenty of space for practically any access control solution. It also has room for a no-break power supply unit and a card collection box (not included).

In order to simplify maintenance and assembly, the column has an internal U-shaped mounting rack with a standard set of holes for prompt mounting of electronic boards. Additional holes can be drilled by the customer to accommodate specific needs.

For access to the mounting rack, use the keys that are provided with the turnstile. Removal and insertion of the rack are extremely easy.



The upper column panels are manufactured in high-impact engineering plastic with customizable stainless steel sheets. The plastic panels are available in green, burgundy, or black. Special color orders are available upon consultation. The front upper panel can have a slot for housing customer supplied magnetic and bar code readers.

The upper cover stainless steel plates are designed for easy configuration and low-cost customization. The plates can be easily punched to accommodate integrator options such as displays, keyboards, biometric sensors, and pictogram LEDs/pictogram indicators, as shown below:

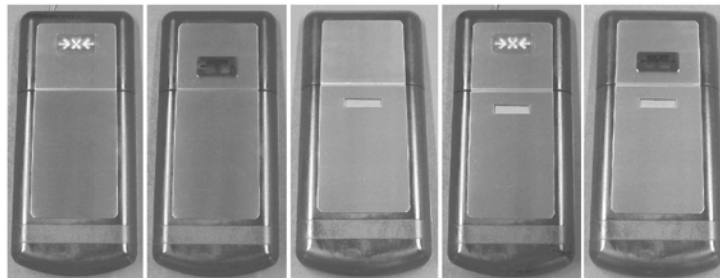

Customization can be carried out with either a third party supplier or with Digicon (subject to additional quotation).

The Catrax Plus is compatible with most technologies currently available. The following optional items can also be ordered: card collection kit, pictogram kit, backlight display, mechanical counter, power supply, control board, and no-break power supply unit.

These options will be described in greater detail in section 5 Installation/Assembly of optional products.

NOTE

For detailed information on the dimensions of CATRAX Plus components, see section 7 Technical Characteristics, page 23.

3.1 CATRAX PLUS OPERATING MECHANISMS

The CATRAX Plus features two operating mechanisms. The basic model (with no control board) employs a bidirectional rotation system with two 12 V electromagnets that activate the locks and two optical sensors that provide the electromagnets with information on turn completion and direction of turn.

An optional microprocessor-based control board is also available. In this case, an "enable turn" signal is sent. If this signal is recognized, the arm will turn from left to right or right to left depending on the signal received. Once half the turn (60 degrees) is completed, a 400 ms return signal is emitted informing the direction of turn. After this signal, the arm will not turn back.

Depending on the turnstile's configuration and model, forcing the arm in the absence of an "enable turn" signal will activate an electromagnet that locks the arm. In this case, the equipment may also emit an audible alarm and/or display a red X on the upper panel display (models with pictogram indicators). A return signal will then be sent, indicating that the turnstile was forced and informing the direction of turn.

CAUTION

The specifications described above refer to optional items manufactured by Digicon. However, products from other manufacturers may also be installed on the CATRAX Plus basic model (including control boards).

4 CATRAX PLUS ASSEMBLY / INSTALLATION

4.1 VISUAL INSPECTION

Depending on the customer's order the CATRAX Plus may include items that are not factory-installed. It is very important to carry out a careful visual inspection of the contents before beginning assembly and installation. Contents should be compared with the checklist provided with the package.

CAUTION

In order to prevent the loss of access keys, bolts and spanners used to assemble the CATRAX Plus, these items are taped to the box containing the arms. Before disposing of any wrapping materials (plastic or cardboard), make sure that you have identified all the items in the checklist.

The figure below shows all the parts that may come with your CATRAX Plus:

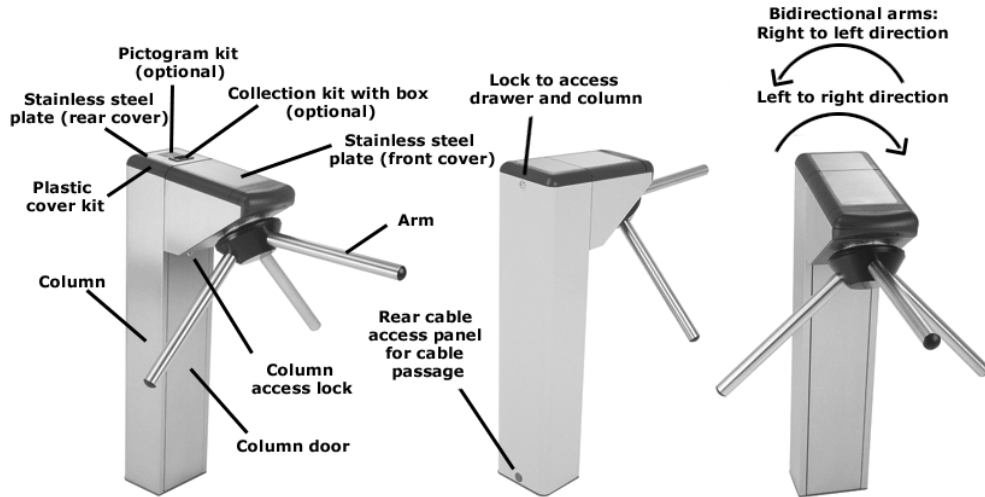

NOTE

In addition to the items indicated above, the CATRAX Plus may include an optional counter, a power supply unit, a control board, a no-break power unit, and a pictogram kit.

4.2 PREPARING THE INSTALLATION SITE

Before installing CATRAX Plus, please verify that:

1. The site chosen for installation is adequate – keep in mind that the turnstile must be installed indoors.
2. There is an energy source or electric outlet close to where the turnstile will be installed.
4. There is enough room (at least 5 cm) between the rear part of the CATRAX Plus column and the wall. This is important to ensure access to the upper panel and rear cable access panel.
5. There is enough room for the arms to turn. For additional details concerning equipment dimensions, see item 7 Technical Characteristics, page 23.
6. The floor has the necessary support structure for anchor bolts (suggested minimum of 4 cm of FCK15 MPa concrete or equivalent).

4.3 INSTALLING THE COLUMN

1. Drill the floor with a 3/8" (9.5 mm) drill and finish with a 1/2" (12.5 mm) drill. Make four holes as indicated in the diagram below.

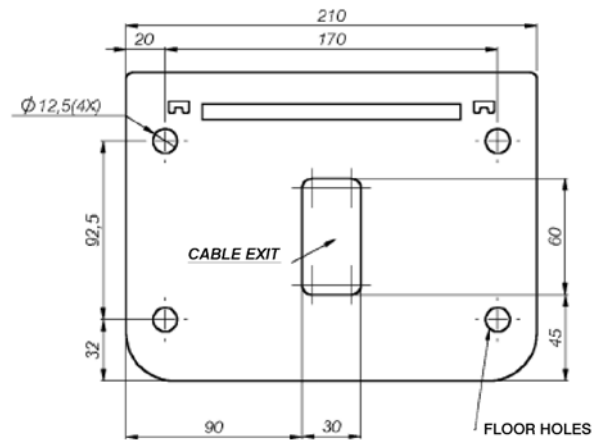

Dimensions in mm.

NOTE

Electrical and communication cables must pass through the cable exit. Check cut-out dimensions to make sure all cables will fit.

NOTE

A heavy-duty steel template for installation of the column may be purchased from Digicon.

2. Clean the holes, removing drilling residues.
3. Place the four anchor bolts in the holes, leaving approximately 25 mm of the anchor bolt out of the hole.

NOTE

Recommended bolts: Tecmart AF38110, 3/8x4".

4. Position the column and fasten it onto the floor with the four bolts that come with the anchor bolts. Use a 3/4" socket wrench or spanner.

4.4 MOUNTING OF ARMS AND COVERS

After installing the column, you may proceed with mounting the arms and plastic covers.

The details of the arms and top front cover and the instructions for assembly appear in the figure below.

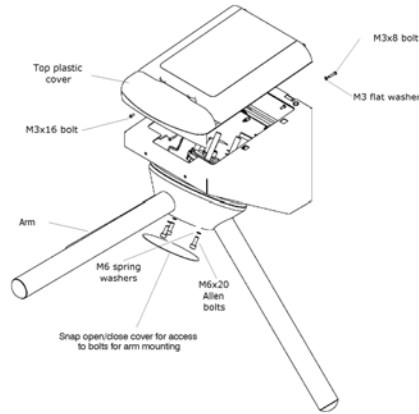

NOTE
Use a #5 Allen wrench to mount the CATRAX Plus.

After that, mount the upper panel rear cover. The following figure shows the cover in detail.

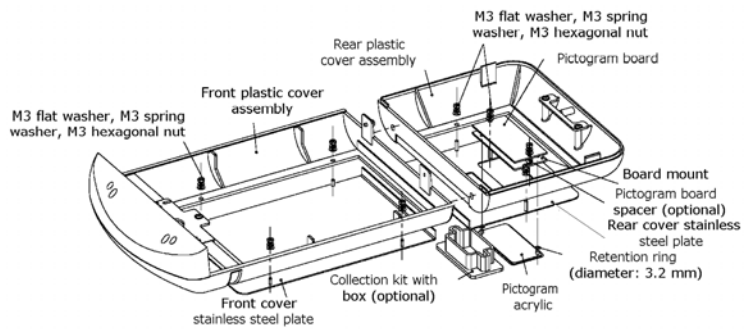

4.5 ACCESS TO THE CATRAX PLUS INTERNAL COMPONENTS AFTER ASSEMBLY

After the CATRAX Plus has been installed and assembled, access to internal components is possible via the rear cover, the front cover, or the column door, using the access keys that come with the equipment.

5 INSTALLATION/ASSEMBLY OF OPTIONAL PRODUCTS

Digicon offers several options to enhance access control and facilitate customization.

5.1 CARD COLLECTION KIT WITH CHUTE

The collection kit with chute has a card and badge collection, retention and storage unit, perfect for visitors or temporary users. The kit is composed of a plastic insertion slot, a solenoid-activated retention mechanism and a storage box. The following figure shows the items that come with the collection kit and may serve as a guide for its assembly.

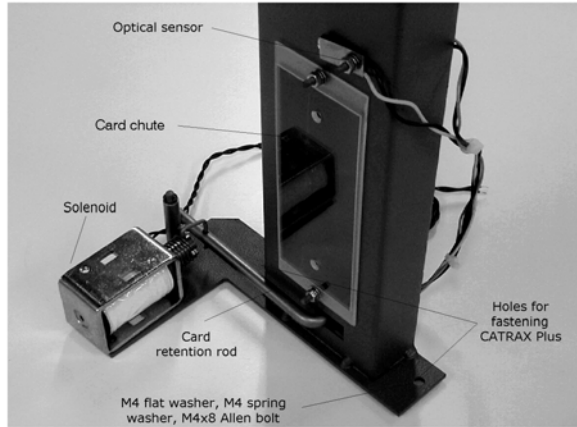

5.1.1 Connecting the card collection box to the control board

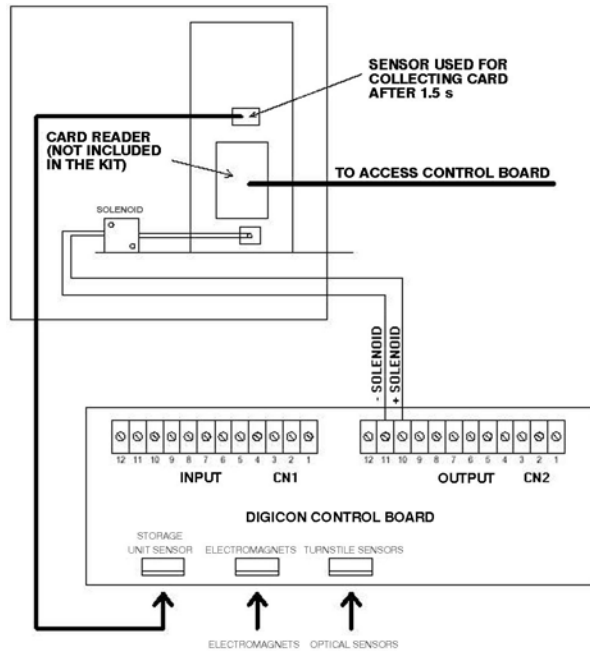

NOTE

The magnetic/bar code reader is not part of the kit.

5.2 PICTOGRAM KIT

The pictogram kit provides visual indication of the direction of turn (green arrows) and turn locking (red X). The pictograms are created using high-intensity LEDs.



For information on assembling the pictogram kit and on the items that come with the kit see the figure referring to the rear cover on page 8.

5.3 COUNTER

A five-digit mechanical counter is available as an optional item for your Catrax Plus.



The counter kit may be mounted in two positions, depending on the direction of flow to be controlled. The figure below shows the items that come with the counter kit and can be used as a guide for its assembly.

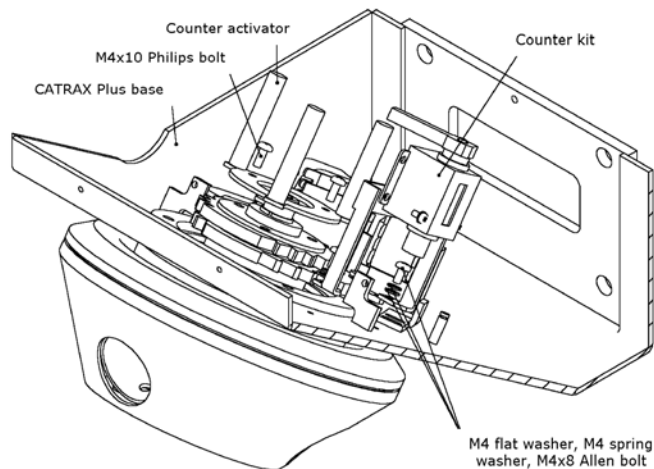

5.4 POWER SUPPLY

This power supply unit was especially projected for the CATRAX Plus. One of the main advantages of this optional item is its input voltage range – between 90 and 250 VAC – and therefore its capability to adapt to the voltage variations that are common in many installation sites.

This reliable power supply unit was carefully tested and developed to work under the most hostile environmental and temperature conditions. The power supply unit is also protected against short circuits and overheating.

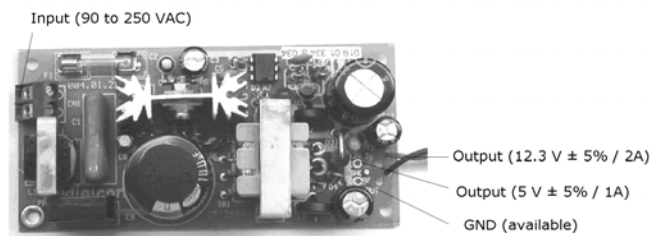

NOTE

The power supply unit can be fastened to the mounting rack provided with the CATRAX Plus.

CAUTION

The power supply unit does not have a dedicated ground connection. Use the mounting rack fastening screw on the turnstile body for grounding.

5.5 CONTROL BOARD

The CATRAX Plus control board was designed to meet the needs of most of the current access control technologies.

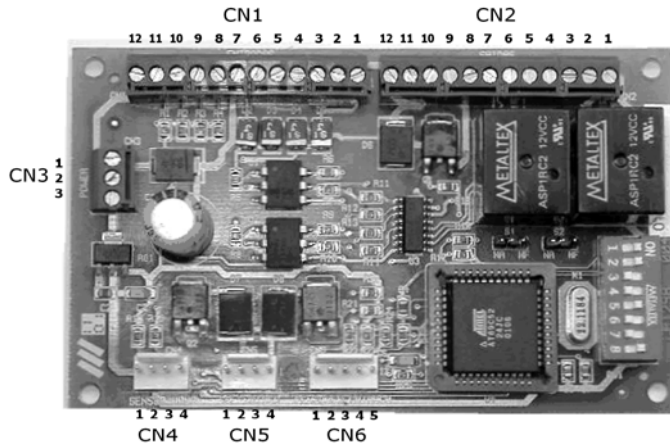

The table below describes the functions of controller board connectors.

Signal	Name/Description
CN1 INPUTS	
1	+Vext1 (enable turn by tension)
2	HAB1 (right to left direction)
3	GND
4	Vext2 (to enable turn by tension)
5	HAB2 (left to right direction)
6	GND
7	+12VDC (available for auxiliary – maximum of 500 mA)
8	CLOCK1 (input for reader – left to right direction)
9	DATA1 (input for reader – left to right direction)
10	CLOCK2 (input for reader – right to left direction)
11	DATA2 (input for reader – right to left direction)
12	GND
CN2 OUTPUTS	
1	N.O. or N.C. contact (HAB1 return)
2	C contact (HAB1 return)
3	N.O. or N.C. contact (HAB2 return)
4	C contact (HAB2 return)
5	Output for X (NPN open collector – maximum of 500 mA) – orange wire
6	Output for (NPN open collector – maximum of 500 mA) – blue wire
7	Output for (NPN open collector – maximum of 500 mA) – green wire
8	+12VDC (power for indicator arrows) – red wire
9	GND (power for indicator arrows) – black wire
10	+ badge collector box solenoid
11	- badge collector box solenoid
12	Audible signal (open collector - NPN)
CN3 POWER – Power input	
1	+12VDC power input
2	GND power input
3	GND

Signal	Name/Description
CN4	CARD CHUTE SENSOR
1	LED anode
2	Box signal
3	GND
4	GND
CN5	ELECTROMAGNETS
1	+ electromagnet 1
2	- electromagnet 1
3	+ electromagnet 2
4	- electromagnet 2
CN6	OPTICAL SENSORS
1	Sensor signal 1
2	LED1 anode
3	Sensor signal 2
4	GND
5	LED2 anode

NOTES

- Optical sensor (CN6) and electromagnet (CN5) cables are supplied with the CATRAX Plus.
- The card chute sensor cable (CN4) is supplied with the card collection kit (ordered separately).

5.5.1 Inputs

The inputs or turn-enabling signals (HAB1 and HAB2) can be triggered/initiated by relay, pushbutton pendant switch contact, or 5 to 24 VAC/DC or 110 to 220 VAC/DC tension pulses.

In order to enable turn through the relay or pushbutton pendant switch contact, make the necessary connection, as shown in the figure below:

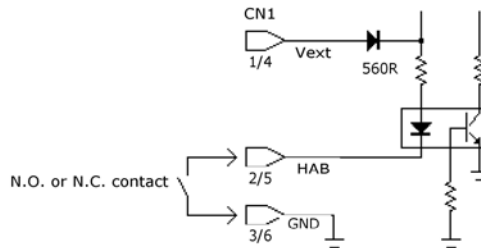

Turn-enabling through tension pulse is shown in the following figure. DC polarity must be observed. For high voltages, use an external resistor (110 to 220 V).

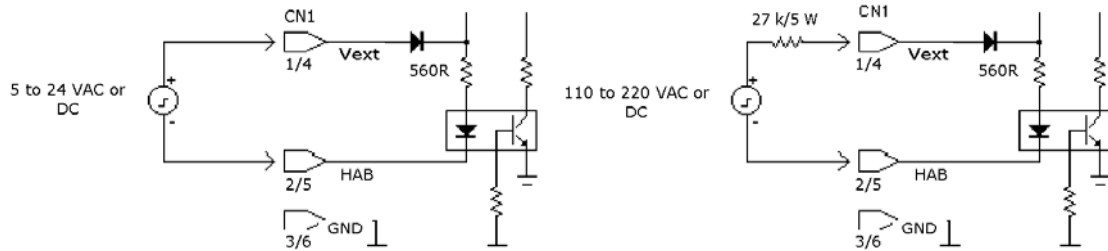

The control board also has inputs for optical sensors (CN6) that monitor turn without mechanical wear, and two optoisolated inputs to release the CATRAX Plus if required.

5.5.2 Outputs

The CATRAX Plus board has outputs for return signals, electromagnets, pictogram indicators, card collection box, and audible alarm.

5.5.2.1 Return signals

The return signals indicate the moment and the direction of turn and are originated at a relay (normally open, N.O., or normally closed, N.C. contact). Connect the outputs according to the figure below:

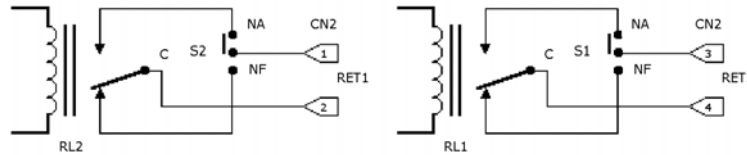

5.5.2.2 Electromagnets

The electromagnets are activated for blocking the turnstile. Unlike traditional solenoids, electromagnets do not cause friction between the spring and the locking device, preventing malfunction. Moreover, they are activated by a transistor rather than by a relay, which prevents burning due to "contacts sticking together" (no mechanical wear).

5.5.2.3 Audible alarm

The audible alarm output is activated by an NPN transistor (maximum of 500 mA) whenever the CATRAX Plus:

- receives a release signal (two brief beeps);
- has not been released and is forced for one second (one-second beeps);
- stops in the middle of a turn for more than two seconds (one-second beeps).

Connect the audible alarm according to the figure below.

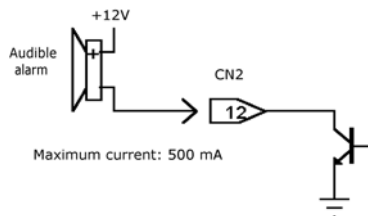

5.5.2.4 Connection diagram

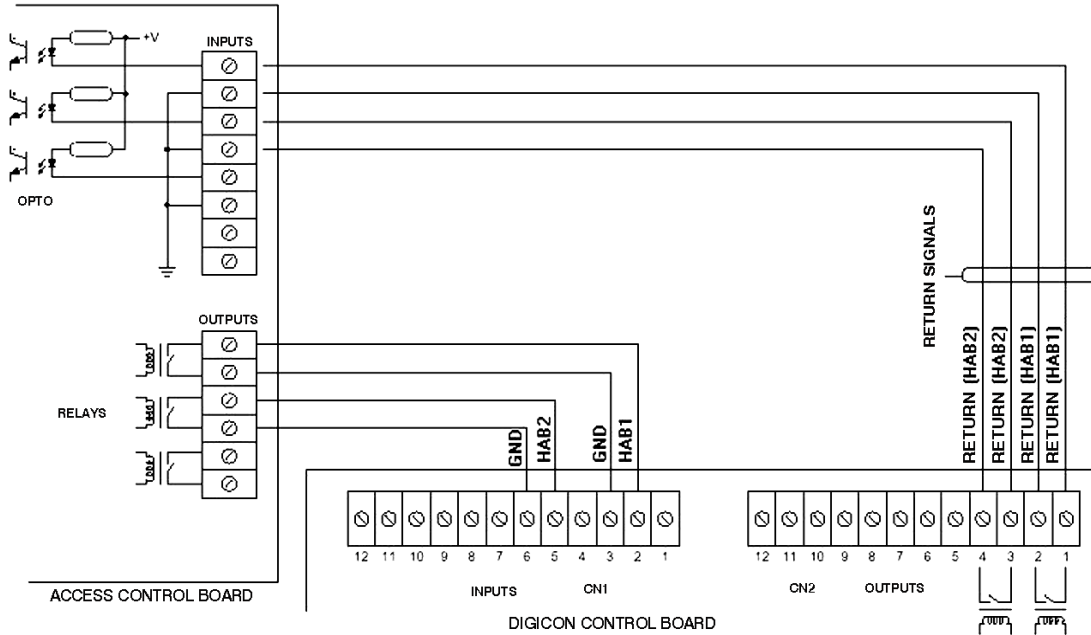

5.5.2.5 Pictogram indicators

Pictogram indicators are activated by NPN transistors (maximum of 500 mA). On activation, a GND signal is sent through the corresponding output.

5.5.2.6 Pictogram connection diagram

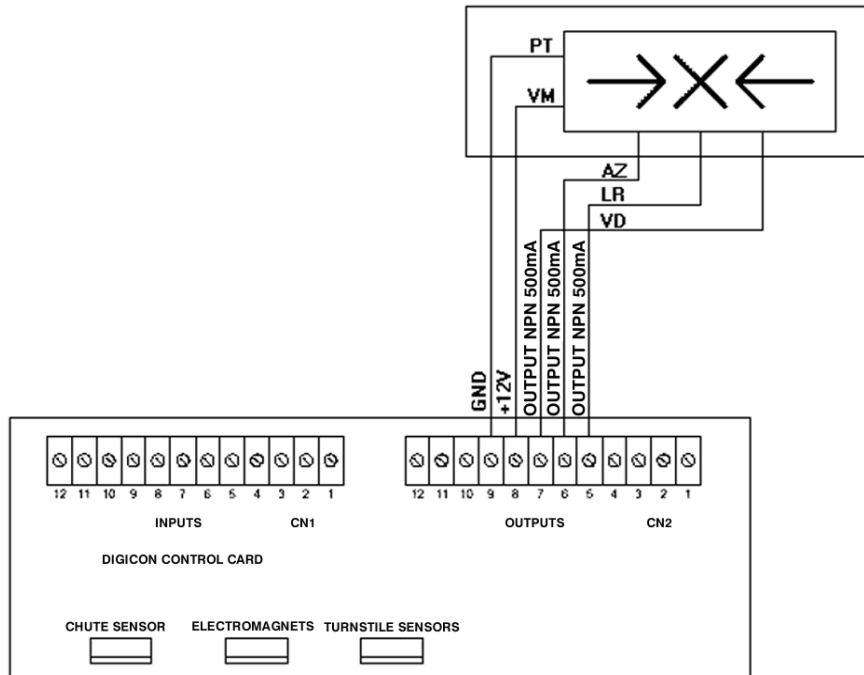

5.5.3 Control board configuration – Dip Switch 1

DS 1 is used to configure the following:

- direction of turn;
- maximum time of passage;
- N.O. inputs (normally open relay or pushbutton pendant switch contacts without input tension) to enable turn in the presence of these signals, or N.C. inputs (normally closed relay or pushbutton pendant switch contacts with input tension) to enable turn in the absence of these signals;
- audible alarm signal if the turnstile stops in mid turn for over two seconds.

The table below describes the position of the switches.

	01	02	03	04	05	06	07	08
Release both directions	-	-	-	OFF	OFF	-	-	-
Lock left to right direction	-	-	-	ON	OFF	-	-	-
Lock right to left direction	-	-	-	OFF	ON	-	-	-
Lock both directions	-	-	-	ON	ON	-	-	-
N.O. inputs	-	ON	-	-	-	-	-	-
N.C. inputs	-	OFF	-	-	-	-	-	-
Enable audible signal in mid turn	-	-	-	-	-	ON	-	-
Disable audible signal in mid turn	-	-	-	-	-	OFF	-	-
Wait for first turn	-	-	-	-	-	-	ON	ON
Wait for 5 seconds	-	-	-	-	-	-	OFF	ON
Wait for 10 seconds	-	-	-	-	-	-	ON	OFF
Wait for 15 seconds	-	-	-	-	-	-	OFF	OFF
Enabling by border	-	-	OFF	-	-	-	-	-
Enabling by level	-	-	ON	-	-	-	-	-

The shaded fields indicate the default configuration of the Digicon board.

5.5.4 Configuration examples

1 – To receive relay pulse (normally open contact), release turn, and wait 10 seconds for turn:

	1	2	3	4	5	6	7	8
Configuration	-	ON	OFF	ON	ON	-	ON	OFF

2 – To always allow turn in clockwise direction and to indefinitely release turn in counter-clockwise on receiving an HAB2 signal:

	1	2	3	4	5	6	7	8
Configuration	-	ON	OFF	OFF	ON	-	ON	ON

3 – To unlock turnstile when the relay contact is closed and to lock arms as soon as the contact is opened:

	1	2	3	4	5	6	7	8
Configuration	-	ON	ON	ON	ON	-	ON	ON

NOTES

- The control board can be fastened to the mounting rack that comes with the CATRAX Plus.

5.6 NO-BREAK POWER UNIT

In situations of power outage, a no-break power unit will allow the CATRAX Plus to continue working for at least four hours (until the battery reaches a tension of 11.4 V). Maximum charge current is 250 mA, and minimum charge time is 5 hours (ideal: 24 hours).

The no-break kit includes a fastening mount, a sealed 12 V/5 Ah battery, and a board.

5.6.1 Anti-panic device

With the no-break power unit, an emergency switch can be connected between wires # 9 and # 10, as shown in the diagram below. This switch is normally off. When activated, it cuts the supply of power to the turnstile, releasing the arms to turn in both directions.

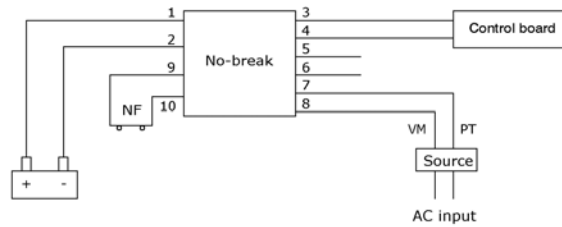

The numbers in the previous figure refer to the following items:

1	+ Battery
2	- Battery
3	+12 V output for turnstile
4	GND output for turnstile
5	+5 V auxiliary output
6	GND auxiliary output
7	GND input from source
8	+VCC input from source
9, 10	Wires used for emergency switch

5.7 DISPLAY

Digicon has developed a board with display for the CATRAX Plus. This board can be used by integrator companies in cases in which the equipment intelligence is located outside the equipment (for example, in a computer). Messages are configured with a serial communication interface and are selected manually (relay).

The backlight display has two 16-character lines (character dimensions 5 x 8 mm). Board supply voltage is 7-24 VDC/100 mA. Relay inputs are available for message selection and clock synchronizing via N.O. contact.

Up to 20 two-line messages can be configured and are activated by relay combinations. The RS-232 or RS-485 outputs are used to configure the messages through the software installed in the PC connected to the CATRAX Plus. The following figures show the front and rear views of the display.

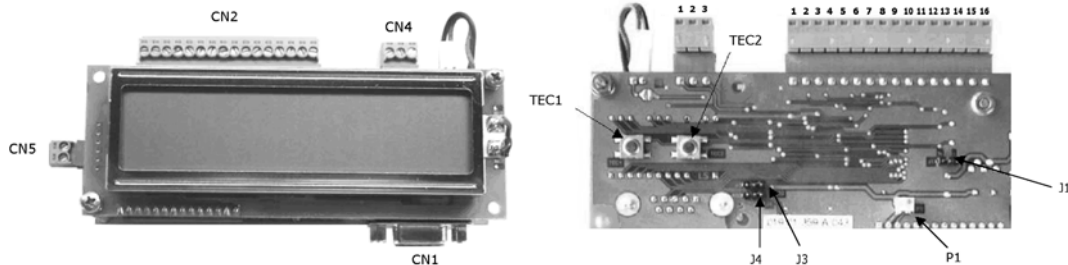

The following table describes the functions of the board connected to the display.

Signal	Name/Description
CN1	RS-232
2	TX
3	RX
5	GND
CN2	INPUTS
1	Input 1
2	GND
3	Input 2
4	GND
5	Input 3
6	GND
7	Input 4
8	GND
9	Input 5
10	GND
11	Input 6
12	GND
13	Input 7
14	GND
15	Synchronicity
16	GND
CN4	RS-485
1	- comm.
2	Ground
3	+ comm.
CN5	POWER SUPPLY
1	Power between 7 and 24VDC
2	GND power supply

NOTE

In CN4, two-way shielded cables must be used; the shielding must be connected with the ground wire.

The following table describes the functions of the board straps.

Strap	Position	Description
J1	Position N	Normal operation
	Position I	Programming mode (firmware upgrade)
J3 e J4	Right	Communication for RS-232
	Left	Communication for RS-485
P1	-	Adjusts the display contrast according to the angle from which one wishes to read the message

The shaded fields indicate the default configuration of the Digicon board.

5.7.1 Display configuration and operation via software

The display operating software can be used to program several messages, configure stand-by messages as well as change the date, time and address on the display. To order the software, write to vendas.aceeso@digicon.com.br.

5.7.1.1 Programming messages

1. Start the display configuration software.
2. On the **Destino** (Destination) field, type in the address of the board on which you want to change the messages.
3. In **Porta** (Port), select the port that will be connected to the display and click on **Conectar** (Connect).

4. Click on the **Mensagem** (Message) menu and **Receber mensagens** (Receive messages). After 5 seconds, the programmable messages configured for the display will appear. Change the desired message and click on **Enviar** (Send).
5. On the **Mensagem** (Message) menu, click on **Habilitar/Desabilitar** (Enable/Disable). The choice between using standard messages or custom messages must be made at this moment.

5.7.1.2 Configuring the stand-by message

The stand-by message appears on the display above the time and date. You may choose to show always the same message or to have a maximum of three different stand-by messages. In order to configure the stand-by message, follow the steps below:

1. Start the display configuration software.
2. On the **Destino** (Destination) field, type in the address of the board where you wish to program the stand-by message.
3. In **Porta** (Port), select the port that will be connected to the display and then click on **Conectar** (Connect).
4. Click on the **Configurações** (Configurations) menu and on **Mensagens de repouso** (Stand-by messages). The first box corresponds to the single message option. Type in the desired message and click on **Enviar** (Send). By clicking on **Múltiplas mensagens** (Multiple messages), it will be possible to program up to three messages, as well as their beginning time.

5.7.1.3 Setting the date and time

1. Start the display configuration software.
2. On the **Destino** (Destination) field, type in the address of the board on which you wish to adjust the clock.
3. In **Porta** (Port), select the port that will be connected to the display and then click on **Conectar** (Connect).
4. Click on the **Configurações** (Configurations) menu and then on **Acertar o relógio** (Adjust clock).

5.7.1.4 Changing the display address

1. Start the display configuration software.
2. On the **Destino** (Destination) field, type in the address of the board whose address you wish to change.
3. In **Porta** (Port), select the port that will be connected to the display and then click on **Conectar** (Connect).
4. Click on the **Configurações** (Configurations) menu and on **Alterar endereço** (Change address). After that, type in the new address. Remember to change the address on the **Destino** (Destination) field too.

5.7.2 Adjusting the display manually

5.7.2.1 Default message selection

To select a default message, all you have to do is switch on the GND (by relay contact, for example) on the inputs corresponding to the message, as shown in the table below:

Inputs							Standard messages	Programmed messages	
1	3	5	7	9	11	13			15
X	-	-	-	-	-	-	-	ACCESS DENIED	Message 1
-	X	-	-	-	-	-	-	DEPOSIT YOUR BADGE IN THE BOX	Message 2
X	X	-	-	-	-	-	-	GO TO RECEPTION	Message 3
-	-	X	-	-	-	-	-	FREE ACCESS	Message 4
X	-	X	-	-	-	-	-	UNDER MAINTENANCE	Message 5
-	X	X	-	-	-	-	-	-	Message 6
X	X	X	-	-	-	-	-	-	Message 7
-	-	-	X	-	-	-	-	-	Message 8
X	-	-	X	-	-	-	-	-	Message 9
-	X	-	X	-	-	-	-	-	Message 10
X	X	-	X	-	-	-	-	-	Message 11
-	-	X	X	-	-	-	-	-	Message 12
X	-	X	X	-	-	-	-	-	Message 13
-	X	X	X	-	-	-	-	-	Message 14
X	X	X	X	-	-	-	-	-	Message 15
-	-	-	-	X	-	-	-	PASS	Message 16
-	-	-	-	-	X	-	-	PASS	Message 17
-	-	-	-	X	X	-	-	PASS	Message 18
-	-	-	-	-	-	X	-	SWIPE BADGE TO RELEASE	Message 19
-	-	-	-	X	X	X	-	-	Message 20
-	-	-	-	-	-	-	-	-	-
-	-	-	-	-	-	-	X	-	Synchronizes the clock

NOTE

Standard messages cannot be removed, only disabled.

5.7.2.2 Common inputs (1, 3, 5, and 7)

The first four inputs work with a four-bit combination; pin 1 is the least significant input and pin 7 is the most significant one.

5.7.2.3 Special inputs (9, 11, and 13)

These inputs can be connected with the pictogram or display outputs. Pins 9 and 11 activate the green arrows or the ACCESS PERMITTED message on the display, when the turnstile is unlocked. Pin 13 activates the red X signal or the SWIPE BADGE TO RELEASE message, when passage is forced.

5.7.2.4 Synchronizing clocks (15)

This function adjusts the clocks in interconnected turnstiles to a full hour when there is a +10 or -10-minute difference in relation to the full hour. If the time difference is larger than 10 minutes, the clocks have to be manually adjusted.

For example, if the time in one turnstile is 8:07 and the time in a second turnstile is 7:59, the synchronizing function will adjust both clocks to 8:00. If the time in one turnstile is 8:50 and the time in a second turnstile is 9:01, the clocks will be adjusted to 9:00. If any of the turnstiles shows time between 8:11 or 8:49 (more than +10 or -10-minute difference in relation to the full hour), the synchronizing signal will not adjust the clocks. In that case, the adjustment must be done manually.

This input also allows adjustment of the clock to DST (Daylight Saving Time), as described below:

- Up to two-second pulse = synchronizes the clock (rounds up time to full hour);
- Two to four-second pulse = sets clock one hour back (end of DST);
- Four to six-second pulse = sets clock one hour ahead (beginning of DST).

5.7.2.5 Adjusting date and time manually

In order to adjust the clock manually, press TEC2 – the digits corresponding to time will blink for 5 seconds. To change the hour, press TEC1 until the desired hour appears, and then press TEC2 to save the setting.

To change the minutes, press TEC2 twice and TEC1 until the desired time appears on the display; then, press TEC2 to save the setting. If necessary, press TEC2 three times to change the day, and so on.

5.7.2.6 Display address

The address that appears on the display can be verified during system initialization or by pressing TEC1.

To adjust the board address manually, press TEC1; the current address will appear for five seconds. To change the address, press TEC2 and then TEC1 until the desired address appears (maximum: 254). Press TEC2 to save the setting.

NOTE

All the boards are associated with address 255 in addition to a programmed address, which may be used, for instance, to change all messages or adjust all clocks at the same time. In the software, all you have to do is send the desired commands to address 255; all displays will be changed simultaneously.

5.7.3 Connection table

To connect the display to the CATRAX Plus, use the same outputs that are used for the pictogram kit:

CATRAX Plus	Display	Signal
CN2 - Output 5	CN2 - Input 13	X
CN2 - Output 6	CN2 - Input 9	Seta
CN2 - Output 7	CN2 - Input 11	Seta
CN2 - Output 8	CN5 - Power 1	+12V
CN2 - Output 9	CN5 - Power 2	GND

6 MAINTENANCE

6.1 PREVENTIVE AND CORRECTIVE MAINTENANCE PROCEDURES

Sphere base – Frequency: every 700,000 cycles

The aim of this procedure is to check on the wear of sphere tracks.

Corrective actions:

1. If there is excessive wear (shards, perforations, steel filings or grooves where the sphere runs), replace the part.
2. If the part does not present wear signs, clean and grease it using bearing grease.

Optical sensors – Frequency: at least once a year (depending on environmental conditions)

This maintenance procedure requires the use of a multimeter. In order to verify the need for corrective actions, it is necessary to measure [the?] CN6 when the turnstile is powered, according to the instructions below:

- Set the multimeter to measure DC voltage of up to 20 V. Next, clamp the black pointer to pin 4 and the red pointer to pin 1 of CN6. Voltage should be lower than 0.8 V (non-obstructed sensors). With the pointers in the same position, force the equipment arms in both directions (in one of the directions, the voltage measured by the multimeter should be higher than 4.5 V).
- Repeat the operation clamping the black pointer to pin 4 and the red pointer to pin 3. The results should be the same as those obtained with pins 4 and 1.
- Verify if the sensors present signs of dust.

Corrective actions:

1. If the measurements do not match the standards described above, replace the sensor.
2. Clean the sensors using a clean brush.

NOTE

In excessively dusty environments, perform this maintenance cleaning procedure more than once a year.

Electromagnets - Frequency: every 700,000 cycles

This maintenance procedure requires the use of a multimeter. Disconnect the CN3 from the control board and verify the resistance of the electromagnets. The value should be between 12.5 and 13.5 ohms on pins 1, 2, 3, and 4 of the electromagnet connector. Once the measurement is complete, CN3 should be connected to the board again.

Corrective actions:

1. Replace the electromagnet if one of the following conditions is observed: incorrect resistance, electromagnet in short-circuit or open.
2. If the electromagnet is not working, verify the board and the tension.
3. Tighten the bolts on the base if the electromagnet is loose.

Electromagnet adjustment (if necessary):

1. Force the lock against the sprocket and the equipment arm until the lock is totally inside the first tooth (until the arm is locked).
2. Next, release the fastening bolts and press the electromagnet against the lock buffer so that all its area gets in contact with the electromagnet.
3. Tighten the bolts again.

Lock assembly – Frequency: every 700,000 cycles

In order to verify the need for corrective actions, you should:

- Verify the correct lock position.
- Check whether the lock is fitted to the sprocket or whether there is apparent wear.

Corrective actions:

1. If the lock is incorrectly positioned, verify the retention ring and the spring that tensions the assembly.
2. If the lock is not fitted to the sprocket, replace the lock or the sprocket.
3. If there are signs of wear on the lock end, replace the lock.

Sprocket assembly – Frequency: every 700,000 cycles

To verify the need for corrective actions, you should:

- Verify the wear of the sprocket teeth.
- Check the backlash between the central shaft, the sprocket and the cotter pin.

Corrective actions:

1. If you observe any signs of wear on the teeth, replace the sprocket.
2. If you notice excess backlash between the sprocket and the shaft/cotter pin assembly, replace the sprocket or the cotter pin. To change the cotter pin, use a pulley puller.

6.2 TROUBLESHOOTING

Defect	Possible cause	Action
CATRAX Plus will not turn on	Power supply cable is not connected properly. Power supply fuse is burnt.	Verify wires and fuse (fuse: 3 A).
CATRAX Plus is locked	Optical sensors are obstructed or defective.	Carry out preventive maintenance procedures in the sensors or contact Technical Assistance.
CATRAX Plus will not activate electromagnet (turnstile cannot be locked)	The cable is broken or the distance between the electromagnet and the lock device is inadequately adjusted.	Adjust the electromagnet or deliver the equipment to Technical Assistance.
The arm will not stay in the correct position.	The base of the sphere is worn, dirty, not properly lubricated, or the spring is broken.	Request replacement of defective part or contact Technical Assistance.
CATRAX Plus will not lock on the first tooth.	The distance between the electromagnet and the lock device is not well adjusted.	Adjust the electromagnet or contact Technical Assistance.

7 TECHNICAL CHARACTERISTICS

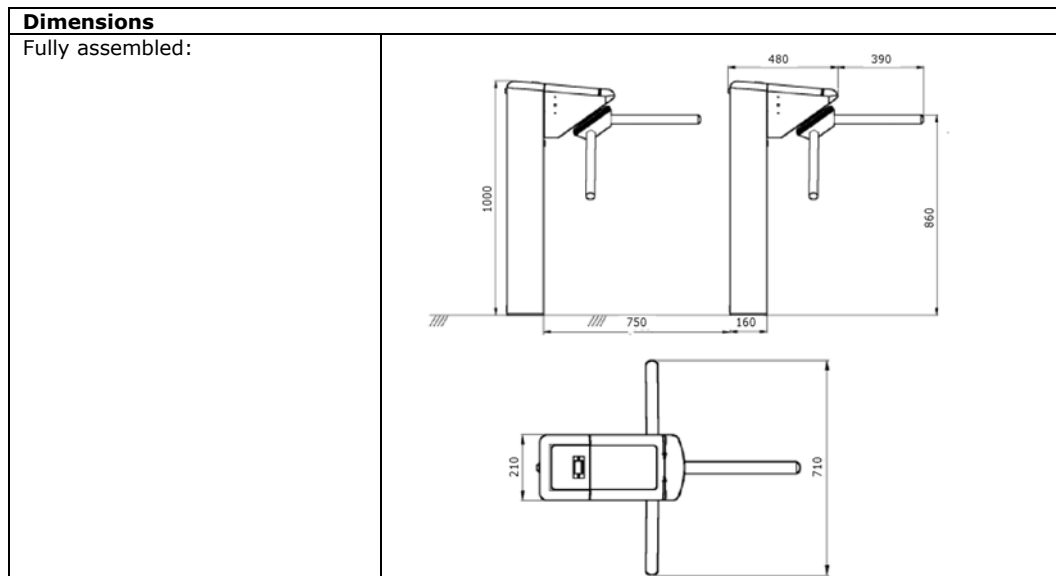

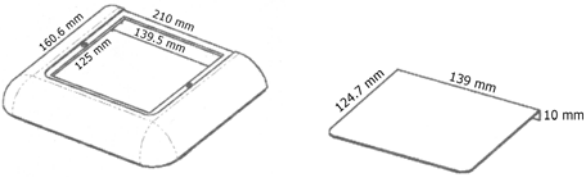
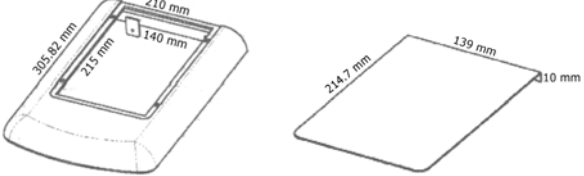
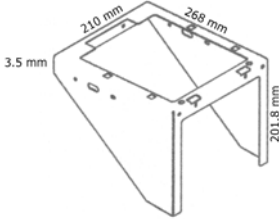
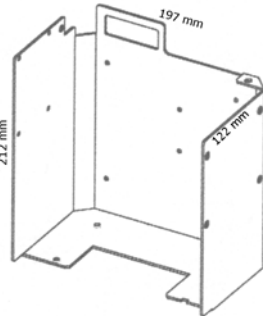
Rear cover and plate	
Front cover and plate	
Tilted cover	
Internal drawer mount	
Packaging	<p>Height: 103 cm Width: 27 cm Depth: 55 cm</p>
Gross weight	<p>37 kg (+ 2 kg of packaging)</p>
Distance between arms	<p>120 degrees</p>
Electromagnet supply voltage	<p>12 V and 2 A</p>
Sensor supply voltage	<p>5 V and 0.5 A</p>
Power supply unit (not included)	<p>Input: 85 V a 250 VAC Output: 12.3 V 5% / 2 A, and 5 V 5% / 1 A Dimensions: 35 x 51 x 105 mm Distance between holes: 43 x 98 mm Diameter of holes: 3.5 mm</p>
Board with display	<p>Power supply: 6 to 24 VDC / 100 mA</p>

