

DRAWING NUMBER: 86-128
 REV: 4
 ECN NUMBER: 00-089

P/N	DESCRIPTION	QTY.
④ 85-213	SPRING - COMPRESSION- RETURN - SOLENOID	1
85-215	WIRE - LINKAGE - PIVOT ARM - ST	1
86-113	LOCK PLATE ASSEMBLY - HIGH - LE - ST	1
86-133	PIVOT & ROLLER ARM ASSEMBLY - HIGH - LE - ST	1
86-141	SOLENOID ASSEMBLY	1
③ 86-147	LOCKING BAR ASSEMBLY - ST	1
SRHM#10-24X1	SCREW - MACHINE - PAN - #10 UNC x 1	2
NH#10-24	NUT - MACHINE SCREW - #10 UNC	2
WL#10 SPLIT	WASHER - HELICAL SPRING - REGULAR - #10	2
85-178	WASHER - THRUST - 3/8 x 3/4 x 1/16	2
85-177	WASHER - THRUST - 5/8 x 1 x 1/16	2
PC3/32X1/2	PIN - COTTER - 3/32 x 1/2	1
PC3/32X1	PIN - COTTER - 3/32 x 1	1

CONTROLLED

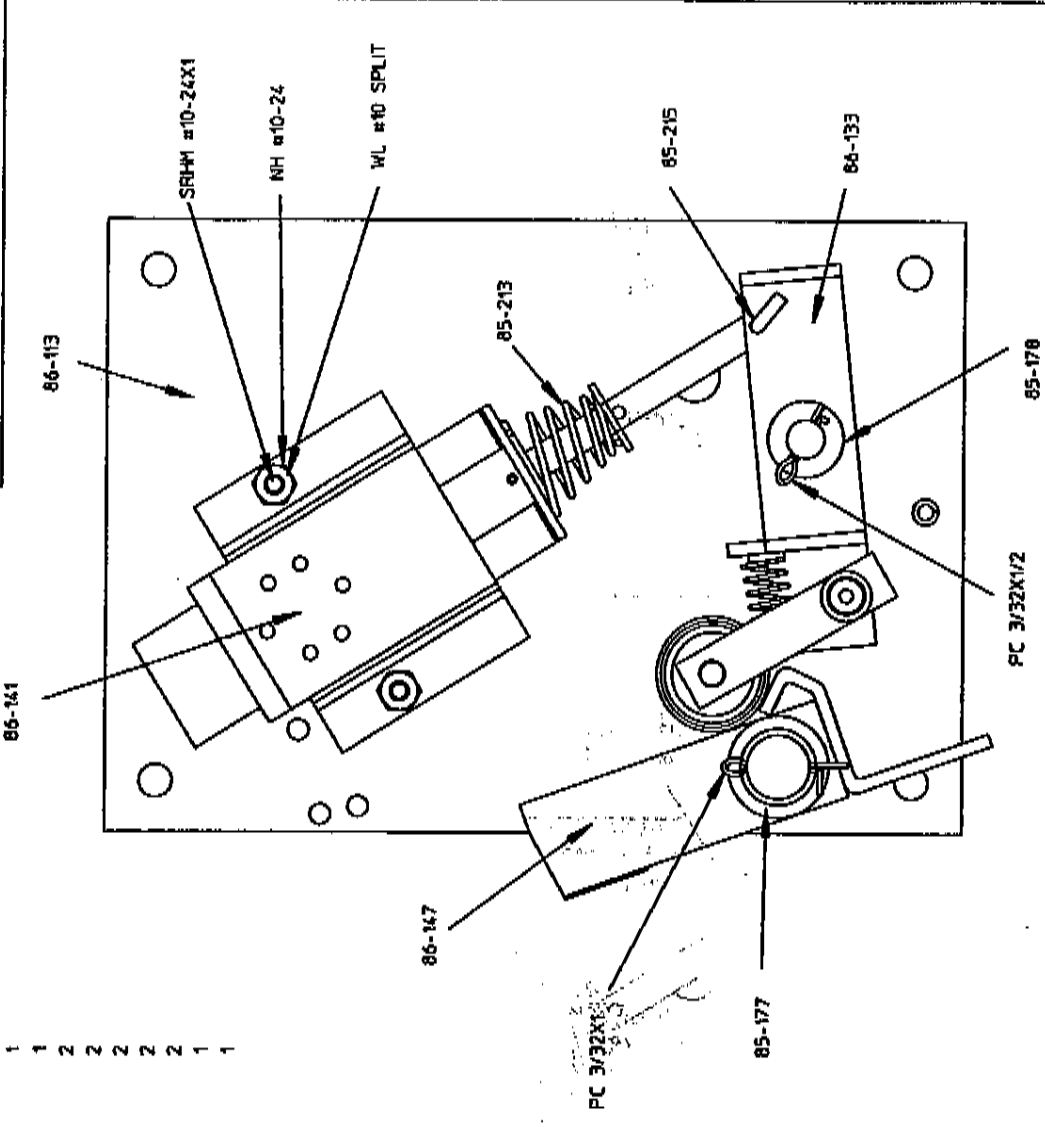

MATERIAL: *****
 FINISH: ****

REV.		DESCRIPTION	BY	DATE
1		UPDATE HARDWARE PART NUMBER DESIGNATIONS	GVB	02/19/99
2		RE-DRAWN AND ELIMINATED ISOMETRIC VIEWS. 86-141 WAS 86-137.	GLS	07/14/99
3		Revised 86-147 Assembly	GVB	03/13/00
4		ADDED 85-213 IDENTIFICATION	CLG	05/22/00

PHILIPS PHILIPS ACCESS CONTROL HARDWARE DIVISION 7041 ORCHARD, DEARBORN, MI. 48126	
DRAWING TITLE: LOCKING MECHANISM ASSEMBLY - HIGH - FAIL-LOCK	
ALL DIMENSIONS ARE IN INCHES UNLESS SPECIFIED	TOLERANCE UNLESS SPECIFIED 0.0 ± 0.060 0.00 ± 0.030 0.000 ± 0.015 0.0000 ± 0.005 ANGULAR ± 0.5°
DRAWN BY/DATE: GLS 07/14/99	CHECKED BY/DATE: GVB 07/14/99
SIZE: MODEL: A ST	DRAWING NUMBER: 86-128
SCALE: # : # ASSEMBLY	REV: 4
-	SHEET: 1 OF 1

THESE DRAWINGS & SPECIFICATIONS ARE THE PROPERTY OF AND PROPRIETARY TO PHILIPS INDUSTRIES, INC. AND ARE NOT TO BE DISCLOSED, REPRODUCED, COPIED OR USED AS THE BASIS OF MANUFACTURE OR SALE OF APPARATUS AND/OR DEVICES, OR OTHERWISE WITHOUT PHILIPS' PRIOR WRITTEN CONSENT.

